

**Indian Institute of Information Technology,  
Design and Manufacturing, Kurnool  
Jagannathagattu, Dinnidevarapadu, Kurnool.**

(An Institute of National Importance Funded By Ministry of Human Resource Development  
Government of India).

PHONE No: 08518-289115 Web Site: [www.iiitk.ac.in](http://www.iiitk.ac.in)



**Tender Document for**

Providing and Fixing Aluminum Partition works in Library and other labs

At IIITDM KURNOOL

(Tender No.: IIITKL/19-20/S&P/Civil/21)

**Telephone: 08518-289115**

**Websites: <http://iiitk.ac.in/home>**

**PART – A**

**(NOTICE INVITING TENDER AND PRE-QUALIFICATION CRITERIA)**

## NOTICE INVITING TENDER

**Tender No.: IITK/19-20/S&P/Civil/21**

**Date: 11.12.2019**

1.0 Sealed tenders are invited on behalf of the Director, IITDM kurnool under Two-bid system (Technical bid and Financial bid) from reputed Contractors for the award of work for “**Providing and Fixing Aluminum Partition works in Library and other labs at IITDM kurnool**” as per schedule, specifications and as per the terms and conditions mentioned in this tender document. Tender forms can be downloaded from the CPP Portal <https://eprocure.gov.in/epublish/app> & [http://iiitk.ac.in/home& https://mhrd.euniwizarde.com/HomePage/ebidSites?siteName=mhrd](http://iiitk.ac.in/home&https://mhrd.euniwizarde.com/HomePage/ebidSites?siteName=mhrd)

The bidders are requested to read the tender document carefully and ensure compliance with all specifications/instructions herein. Non-compliance with specifications/instructions in this document may disqualify the bidders for the tender exercise. The Director IITDM Kurnool, reserves the right to select the firm or to reject any bid wholly or partly without assigning any reason. Incomplete tenders, amendments and additions to tender after opening or late tenders are liable to be ignored and rejected.

<b>Name of Work</b>	<b>Completion Period</b>	<b>EMD</b>	<b>Date of Sale of Tender Document</b>	<b>Date of Submission &amp; Opening</b>
<b>Providing and Fixing Aluminum Partition works in Library and other labs at IITDM Kurnool</b>	<b>30 days</b>	<b>26600</b>	<b>11.12.2019-02.01.2020 upto 2 PM</b>	02/01/2020 up to 14:00 hrs and opening on 03/01/2020 at 11:30 hrs.

### **2.0 PRE QUALIFICATION CRITERIA**

- 2.1. The tenderer must be a Goods and Services Tax (GST) registered firm / company. Sub-authorization is not accepted.
- 2.2. The tenderer should have had average annual financial turnover of not less than Rs. 8.0 Lac during the last three years. The tenderer should attach copy of audited/ITCC Certificate for the last three years duly attested by Chartered Accountant.
- 2.3. The tenderer is required to produce and attach solvency certificate for minimum value of Rs. 3.20 Lac from the scheduled bank duly attested by the Chartered Accountant or Senior Branch Manager of the scheduled bank. Refer “Annexure-IV”. The certificate should not be more than six months old from the date of publication of tender.
- 2.4. The tenderer should have completed at least;  
Three similar works each of value not less than Rs. 2.24 Lac

OR

Two similar works each of value not less than Rs. 3.36 Lac

OR

One similar works of value not less than Rs. 4.48 Lac

in the last 3 years (i.e. Similar work means Aluminum Partition work in any other Govt. Department / private universities, PSUS, IITS,IIITS,NITS,IISER ,ETC during last three years). Attested copies of the completion certificates issued by the Executive Engineer/Head of department are required to be enclosed with the technical bid. The tenderer should also give complete details of the concerned authority such as name with designation, valid address, telephone/ mobile number with STD Code, etc. The completed works will be open to inspection and in case works is not up to the standard, the tender will summarily be rejected & no queries will be entertained in this regard. Refer "Annexure-V"

2.5. The firm should not have been blacklisted, debarred, declared non performer or expelled from any work of Union Government/ State Governments/ PSUs etc. during the last 5 years. They should also submit a self-declaration on its letter head for the same. The firm should also provide information regarding litigation / arbitration cases for the last five years as per Annexure-VI.

### **Notification of Amendments**

If any modification or amendment is made to the tender document, the same will notified on the IIITDM Kurnool web site only and no separate advertisement will be released for the same. Prospective bidders are therefore advised to regularly visit the IIITDM Kurnool web site for any such updates.

### **Submission of bids.**

4.1. Under the two bid system, the bidders are required to submit their 'Technical bid' and 'Financial bid' separately. All the documents related to technical bid (i.e. Eligibility criteria & Technical details) and financial bid should be put in two separate envelopes duly marked as 'Technical bid' and 'Financial bid' respectively. Both the envelopes shall then be sealed in one outer (main) envelope which should be super subscribed clearly with the name of work and the NIT reference number addressed to the Director, IIITDM Kurnool. The outer envelope shall contain the name and postal address of the tenderer with Phone/ Mobile/ Fax numbers and e-mail address, if any.

4.2. The 'Technical bid' should consist of the following documents:

- a. Application form along with documents relating to eligibility criterion (as per Annexure I to VI).
- b. Bid Security (EMD).
- C. Power of attorney of person authorized to sign the Bid.
- d. Complete Tender Document (Part – A to H) duly signed and stamped.

4.3. The 'Financial bid' should contain the following documents:

- a. Price bid as per the prescribed format (Part 'G').

4.4. The last date for submission of bids duly complete in all respect is 28/12/2019 up to 14.00 hrs. The bid should be valid and open for acceptance for a period of 90 days from the date of opening the technical bid.

### **5.0 Opening of Technical bid.**

5.1. Technical bid of all tenderers shall be opened on 30/12/2019 at 11:30 hrs. at IIITDM, Kurnool in presence of tenderers or their authorized representatives. A two stage screening process will be adopted for evaluation of technical bid as discussed under clause - 6.0.

#### **6.0 Evaluation of Technical bid**

##### **6.1. Screening of pre-qualification documents**

6.1.1. At this stage the bid will be evaluated for compliance with the minimum pre-qualification criteria as listed above. The screening will be done purely on the basis of documentary evidence submitted by the tenderer along with his technical bid.

6.1.2. The decision of Bid Evaluation Committee with regard to the evaluation of bids will be final and no correspondence will be entertained in this regard.

### **7.0 Opening of Price bid**

7.1. The price bid of final short listed bidders only will be opened at a date and time to be decided by the Competent Authority and will be communicated to the concerned parties accordingly.

### **8.0 Evaluation of price bid and award of work**

8.1. The work will be awarded to the tenderer whose bid has been determined to be eligible and to be substantially responsive to the tender documents and who has offered the lowest evaluated bid. Corrigendum/amendments etc., if any, will be notified only on the IIITDM Kurnool web site and no separate advertisement will be made for the same. All prospective bidders are therefore advised to regularly visit the IIITDM Kurnool web site (i.e. [www.iiitk.ac.in](http://www.iiitk.ac.in)) for any future information or update.

Note: - 1. The tenderers should sign all documents with stamp otherwise their tenders will be rejected without any reply.

**Sd/-  
Registrar-in-charge**

**Signature of tenderer with Seal & Date**

**PART – B**

**(INSTRUCTIONS TO BIDDERS)**

## INSTRUCTIONS TO BIDDERS

- I. The Tenderer should sign and stamp each page of the tender documents.
- II. The Tenderer may furnish any additional information, which he thinks is necessary to establish his capabilities to successfully complete the envisaged work. He is however, advised not to furnish superfluous information. No information shall be entertained after submission of tender documents unless it is called for by the IIITDMKURNOOL.
- III. Any information furnished by the tenderer found to be incorrect either immediately or at a later date, would render him liable to be debarred from tendering/taking up of work in IIITDM Kurnool.
- IV. Any variation in the terms and conditions of the general/special conditions for payment, tender fees, security deposit, etc. is not acceptable to IIITDM Kurnool and such tenders will be rejected straight away.
- V. IIITDM Kurnool reserves the right to award the contract in full or in part as per the decision of the Competent Authority.
- VI. IIITDM Kurnool is not responsible for any postal delay in receipt of the application / receipt of tender documents etc. It is the responsibility of tenderer to make sure that the tender is received in time.
- VII. The contractor has to inform contact no. and the person to be contacted in case of any query
- VIII. The tenderer shall attach the copy of PAN Card, GST registration.
- IX. Acceptance of tender shall rest with the IIITDM Kurnool which shall not be bound to accept the lowest tender and reserves to itself the right to reject any or all tenders received without assigning any reasons therefore.
- X. Incomplete tenders are liable to be rejected.
- XI. Any bid received after the deadline for submission of bids, will be rejected and/or returned to the tenderer.

**Sd/-**

**Registrar-in-charge**

Signature of tenderer with Seal & Date

**PART – C**

**(GENERAL CONDITIONS OF CONTRACT)**



## GENERAL CONDITIONS OF CONTRACT

### 1.0 CONTRACT DOCUMENT

1.1 The terms 'Contract document' means the Notice Inviting Tender, Tender form, Instructions to bidders, Special Conditions, General Conditions of Contract, Specifications, Price Schedule and Drawings and Articles of Agreement.

1.2 The Contractor shall mean the sole proprietor, or firm or company whether incorporated or not, undertaking the works and shall include the legal representative or such individual successors, heirs, administrators or assignees of such sole proprietor, firm or company, as the case may be or the persons composing such firm or company of the successors of such firm or company and the permitted assignees of such individual or firms or company.

**2.0 Contractor shall strictly conform to the specification, price schedule, general and special terms and conditions, if any, and any other matter contained in the tender documents issued by the IIITDM Kurnool.**

**3.0 The Bid Security (Earnest Money) and Performance Security are as follows:**

A) Bid Security (Earnest Money Deposit): Rs. 26,600/-

B) Performance Security: 10% of Tender Amount

### 4.0 BID SECURITY (EARNEST MONEY DEPOSIT)

4.1. Earnest money along with the tender will be accepted only in the form of demand draft drawn in favor of Director, "IIITDM Kurnool" drawn on a Nationalized/Scheduled bank. The demand draft shall be payable at Kurnool. EMD is exempted for NSIC / MSME firms for that valid certificate should be furnished.

4.2. The bid securities of unsuccessful tenderer will be returned as promptly as possible as but not later than 30 days after the expiry of the period of bid validity prescribed by IIITDM Kurnool.

4.2. The bid securities of unsuccessful tenderer will be returned as promptly as possible as but not later than 30 days after the expiry of the period of bid validity prescribed by IIITDM Kurnool.

4.4. Withdrawal or modification of offer by the tenderer during the interval between the deadline for submission of bids and expiry of the period of bid validity will not be permitted and will result in the forfeiture of its bid security.

## **5.0 PERFORMANCE SECURITY AND SECURITY DEPOSIT**

5.1. The contractor will be required to furnish performance security as per prescribed format for an amount equal to 10% of the estimated value of the work in the form of CDR/FDR/DD/bank guarantee (of nationalized/ Scheduled Bank in a standard format) within two weeks from the date of signing/execution of a work agreement. The performance security should remain valid for a minimum period of one year (i.e. equal to completion period) plus three months of claim period from the date of award of contract.

### **5.2. Agreement. (Refer Annexure 'VII')**

5.3. The performance security will be released after the completion of work and issue of completion certificate.

5.4. Failure of the successful contractor to lodge the required Bank Guarantee shall constitute sufficient grounds for the annulment of the Award and forfeiture of the Bid Security, in which event the IIITDM Kurnool may make the Award to the next lowest evaluated tenderer or, if there are no other tenderer, call for new bids.

5.5. In the event of breach of contract by the contractor, the performance security will liable to be forfeited by IIITDM Kurnool.

5.6. The contractor whose tender is accepted will also be required to furnish by way of Security Deposit for the fulfillment of his contract, an amount equal to 10% of the tendered value of the work. The Security deposit will be collected by deductions from the running bills as well as final bill of the contractor at the rates mentioned above

5.7. The Security Deposit will be released after the expiry of the Defects Liability period of work (i.e. 12 Months) subject to satisfactory fulfillment of its obligations by the contractor under the work.

## **6.0 DRAWINGS**

6.1. All the drawings are enclosed with the tender document and the contractor must furnish detail bar chart showing the various activity w.r.t. times and he must organize co-ordination meeting at the site to review the progress of work.

## **7.0 TIME FOR COMPLETION OF CONTRACT**

7.1. Time for completion of total work shall be 30 days from the date of award of contract. Completion time for each work order shall be mutually decided between IIITDM Kurnool and the Contractor depending upon the value and urgency of the work. However, the maximum period will be allowed not exceeding 45 days from the date of issuing work order.

## **8.0 TIME AND EXTENSION FOR DELAY**

8.1. If in the opinion of the Registrar-in-Charge the works is delayed by:

- a. Force majeure.
- b. Reasons of civil commotion, location combination of workers on strike or lock-out affecting any of the building trades.
- c. In consequence of the contractor for not having received in due time necessary instructions from the Registrar-in-charge for which he shall have specifically applied in writing.
- D. Reasons of Registrar-in-charge instruction

The Registrar-in-charge shall make a fair and reasonable extension of time for completion of the contract works. Then upon the happenings of any such event causing delay, the Contractor shall immediately give notice thereof in writing to the Registrar-in-charge but shall nevertheless use constantly his best endeavor's to prevent or make good the delay and shall do all that may be reasonably required to the satisfaction of the Registrar-in-charge to proceed with the works.

8.2. Request for rescheduling of date of completion and extension of time, to be eligible for consideration, shall be made by the Contractor in writing immediately after the happenings of the event causing delay. The Contractor may also, if practicable, indicate in such a request the period for which extension is desired.

8.3. In such case, the Registrar-in-charge may give a fair and reasonable extension of time and reschedule the completion date. Such extension shall be communicated to the Contractor by the Registrar-in-charge in writing within 1 month of the date of receipt of such a request. Non-application by the Contractor for extension of time shall not be a bar for giving a fair and reasonable extension by Registrar-in-charge and this shall be binding on the Contractor.

## **9.0 COMPENSATION FOR DELAY**

9.1. Time is the essence of the contract. The time allowed for the work shall be strictly followed otherwise the Contractor shall be liable to pay compensation at the rate of 0.2 % of the ordered value of the work per day of delay on the part of the contractor subject to a maximum of 5 % of the total ordered value. The decision of Registrar-in-charge about the delay shall final and binding.

9.2. If the contractor after award of work fails to deliver any item / part of the work within the time period allowed, IITDM Kurnool reserves the right to remove that particular component from the scope of main contractor and get it done through some alternative resources at the cost of main contractor.

## **10.0 TECHNICAL SPECIFICATIONS AND STANDARDS**

10.1. The materials & services to be provided by the tenderer under this contract shall conform to the technical specifications as laid down under this tender document and should be carried out to the complete satisfaction of the Registrar-in-charge.

## **11.0 WORK OPEN TO INSPECTION**

11.1. All work under or in course of execution or being executed in pursuance of the contract shall at all times be open to inspection and supervision by the Registrar-in-charge and his authorized subordinates, and the Contractor shall at all times during the usual working hours, and at all other times at which reasonable notice of the intention of the Registrar-in-charge or his subordinate to visit the works shall have been given to the contractor, either himself be present to receive order and instructions, or have a responsible agent duly accredited in writing, present for that purpose. Order given to the contractor's agent shall be considered to have the same force as if the same had been given to the Contractor himself.

11.2. All works shall be executed subject to the approval in all respect of the Registrar-in-charge who shall be entitled to direct at what point or points and in what manner these are to be commenced, and carried out from time to time.

## **12.0 INSPECTION, TESTING AND QUALITY CONTROL**

12.1. IIITDM Kurnool and/or its nominated representative(s) will, inspect and/or test the work / material to confirm their conformity to the tender specification at no extra cost to the IIITDM Kurnool. The Inspection Authority to be designated by the IIITDM KURNOOL shall specify what inspections and tests are required and where they are to be conducted. The IIITDM Kurnool shall notify the contractor in writing in a timely manner of the identity of any representatives retained for these purpose. All work / material shall be tested as stipulated in the latest specification of, Govt. /institutes.

12.2. The inspections and tests may be conducted on the premises of the tenderer or its subcontractor(s) or at the point of delivery. If conducted on the premises of the tenderer or its subcontractor(s), all reasonable facilities and assistance, including access to drawings and production data shall be furnished to the Inspectors at no charge to the IIITDMKURNOOL.

12.3. The representative of institute shall inspect or test the items, which fail to conform to the specifications. The IIITDMKURNOOL may reject such items and the tenderer shall replace the rejected items, at no cost to the IIITDMKURNOOL, within a stipulated time period.

12.4. The IIITDM KURNOOL right to inspect, test and where necessary, reject the items after its arrival at the final destination shall in no way be limited or waived by reason of the items having previously been inspected, tested and passed by IIITDM KURNOOL or its representatives.

12.5. Nothing shall in any way release the tenderer from Guaranty or other obligations under the contract.

12.6. The IIITDM KURNOOL shall be the final authority to reject full or any part of the item which is not conforming to the specifications and other terms & conditions.

12.7. No payment shall be made for rejected items. Rejected items must be removed by the contractor within one weeks of the date of rejection at their own cost and replace immediately. In case these are

not removed, these will be auctioned at the risk and responsibility of the contractor without any further notice.

### **13.0 PACKING AND MARKING**

13.1. The packing of items to be supplied directly at site, should be strong and durable enough to withstand, without limitation, the entire journey during transit including trans-shipment (if any), rough handling, open storage etc. without any damage, deterioration etc. As and if necessary, the size, weights and volumes of the packing cases shall also take into consideration, the remoteness of the final destination of the supplied Items and availability or otherwise of transport and handling facilities at all points during transit up to final destination as per the contract.

13.2. The quality of packing, the manner of marking within & outside the packages and provision of accompanying documentation shall strictly comply with the requirements as per site condition. In case the packing requirements are amended due to issue of any amendment to the contract, the same shall also be taken care of by the tenderer accordingly.

13.3. Packing instructions: The tenderer shall make separate packages for each consignee (in case there is more than one consignee mentioned in the work order) and mark each package on three sides with the following with indelible paint of proper quality:

- a. contract number and date
- b. brief description of items including quantity
- c. packing list reference number
- d. country of origin of supplied items
- e. consignee's name and full address
- f. tenderer's name and address.

### **14.0 WATER & POWER FOR THE WORK**

IIITDMKURNOOL shall provide power & water at one point for the proper execution of the work free of cost under normal circumstances if available at site. In case IIITDM KURNOOL is not in a position to supply the water and / or power, the contractor will make his own arrangement so that the work does not suffer. However no claim of the contractor whatsoever shall be entertained by IIITDM KURNOOL on this account.

## **15.0 CO-ORDINATION**

Work shall be carried out in such a manner that the work of other agencies operating at the site is not hampered due to any action of the contractor. Proper co-ordination with other agencies will be contractor's responsibility. In case of any dispute the decision of IIITDM KURNOOL shall be final & binding on the contractor.

## **CLEARANCE OF SITE**

The contractor shall have to remove all waste (Melba) and other unwanted material from site of work before handing over the installation to the IIITDMKURNOOL. The work shall not be treated as complete in all respects unless these requirements are fulfilled by him. In the event of contractor failing to do so, the IIITDMKURNOOL shall have right to get the site cleared at the cost of contractor.

## **SAFETY CODE, LABOUR CAMPS SANITARY ARRANGEMENTS**

The Contractor shall follow the Safety Code and Model Rules for the Protection of health and Sanitary arrangement for Workers as prescribed by the CPWD as regard to safety code and first aid facilities. In case, the Contractor fails to make the aforesaid arrangement, the Director ,IIITDM KURNOOL shall be entitled to do so at the risk, responsibility and cost of the Contractor. Determent panel and legal action shall be taken in the event of any failure on the part of the contractor to discharge the safety obligations which are laid down in the contract.

## **REMOVAL OF PERSON**

The Registrar -in-charge may require the Contractor to remove from the site of the work any person or persons in the Contractor's employment who may found to be incompetent or due to misconduct and the Contractor shall forthwith comply with such requirement / instructions.

## **WATCH AND WARD**

The contractor shall be responsible for watch and ward of all the works and various materials till complete handing over the works to the IIITDMKURNOOL.

## **OTHER CONDITION**

Each of the prospective tenderers, who submit their bid for this tender, shall be required to deposit its sample of material for mockup screening at IIITDM KURNOOL office during the evaluation of its Technical bid (i.e. just after opening of Technical bid the tenderers will be intimated his mockup schedule to IIITDM KURNOOL). He may also be required to give the brief technical specification details & presentation to the Bid Evaluation Committee Members during such mockup show for those items he has submitted his bid to IIITDM KURNOOL for technical acceptability as per the tender specifications, failing which bid shall be liable to be rejected. All the cost for organizing such requested mockup show at IIITDM KURNOOL shall be solely borne by the prospective tenderers himself. IIITDM KURNOOL shall not pay or bear any cost regarding the same.

The time for supply of items is very important factor to the IIITDM KURNOOL. Only those tenderers, who are confident and willing to supply the requested items to IIITDMKURNOOL within the prescribed time period after the receiving of confirm supply order from IIITDMK are requested to participate in this

Tender.

Payments to the contractor shall be made as per the Clause – 7 & 9 of the CPWD updated General Conditions of Contract.

The submission of tender shall be deemed to be an admission on the part of the bidder that it has fully acquainted with the contract terms and no claim other than what stated in the tender shall be paid in the event of award of Contract.

For elaboration of any items of the General condition of Contract, reference shall be made to CPWD manual. The Contractor shall in advance seek clarification on any elaboration.

The successful tenderer is responsible to provide the required manpower with qualified persons to meet the requirements of the maintenance of the installation during the guarantee period. The contractor shall provide any cleaning materials required. Tools required for the maintenance shall be arranged by the contractor (spanner set, cutting pliers, pipe wrenches etc.).

The staff to be engaged on this work shall have full knowledge and experience of the work in which they are engaged.

No subletting or subcontracting of the work will be permitted without the express consent of IIITDMKURNOOL.

All dispute arising under this contract will be subject to the jurisdiction of ANDHRAPRADESH High Court.

In case this tender document does not contain a provision or terms for dealing with a situation that may arise during the execution of the works, the relevant provisions contained in the CPWD manual or any other laws/rules shall be followed in such cases and the same will be binding on the Contractor.

**Sd/-**

**Registrar In charge**

**PART – D**  
**(SPECIAL CONDITIONS OF CONTRACT)**



## **SPECIAL CONDITIONS OF CONTRACT**

### **1.0 PRICES**

1.1 Tenderers price shall be deemed to include cost of all materials, tools and tackles, taxes, delivery charges etc. whether specifically mentioned or not. The tenderer shall also include in his price all taxes, duties or other levies which are legally leviable on the tendered work. The prices will remain firm & fixed during the currency of work. However, in case of any statutory variation in Taxes/Duties after the last date of submission of Tender the same shall be adjusted. The Tenderer may therefore indicate the percentage cost of material and labor to be considered for the payment of adjustment of statutory variation in Taxes/Duties as mentioned above. The prices should be quoted on F.O.R destination basis. (i.e. IITDM KURNOOL ).

### **2.1 DEVIATION**

The deviation in quantities of respective work order shall be allowed up to the extent of +10% on the awarded rates.

### **3.1 PAYMENT AND DEDUCTIONS**

4.1 The payment will be made to the contractor within 30 days (on submission of bills with measurements etc. complete in all respect) of successful completion of work(s) in all respect as per the work orders issued under this work and satisfaction of Registrar In charge.

### **5.1 Procedure for submission of bills**

- a. Within 30 days of successful completion of the work against any work order issued under this work, the contractor will have to submit bill to the Registrar-in-charge for verification and payment.
- b. Measurements shall be in unit system as mentioned in schedule of work and respective bills as per the work order issued under work shall be prepared and submitted by the contractor for payment based on joint measurement.
- c. The Registrar-in-charge shall take or cause to be taken the requisite measurement for the purpose of having the same verified and the claim as far as admissible to be adjusted.
- d. If the contractor does not submit the
- e. bill within the time fixed aforesaid, the Registrar-in-charge may depute a subordinate to measure up the said work in the presence of the contractor whose counter signature to the measurement list will be sufficient warrant and the Registrar-in-charge may prepare the bill. This shall be done at the cost of the contractor and the failure of the Contractor to participate and countersign the measurements shall foreclose his right to challenge them at any stage thereafter.
- f. Before making payment, security deposit @ 10% will be deducted from each bill and the same will be released on satisfactory completion of guarantee period. Further, deduction towards taxes, service tax

etc as applicable, will be made before release of payment to the contractor.

## **6.1 DEVIATION / VARIATION / EXTRA ITEMS / SUBSTITUTE ITEMS AND PRICING**

### **6.2 GENERAL**

The Registrar-in-Charge shall have power to make alteration in, omissions from, additions to, or substitutions from the original specifications, drawings, designs and instructions that may appear to him to be necessary or advisable during the progress of the work, the contractor shall be bound to carry out the works in accordance with any instructions given to him in writing signed by the Registrar-in-charge and such alterations, omissions, additions or substitutions shall form part of the contract as if originally provided therein and any altered, additional or substituted work which the contractor may be directed to do in the manner specified above as part of the works, shall be carried out by the contractor on the same conditions in all respects including price on which he agreed to do the main work except as hereafter provided.

### **6.3 EXTRA ITEMS / PRICING**

In the case of extra item(s) the contractor may within fifteen days of receipt of order or occurrence of the item(s) claim rates, supported by proper analysis, for the work and the Registrar-in-charge shall within one month of the receipt of the claims supported by analysis, after giving consideration to the analysis of the rates submitted by the contractor, determine the rates on the basis of the market rates and the contractor shall be paid in accordance with the rates so determined.

### **6.4 SUBSTITUTE ITEMS/PRICING**

a. In case of substituted items, the rate for the agreement item (to be substituted) and substituted item shall also be determined in the manner as mentioned in the aforesaid Para.

b. If the market rate for the substituted item so determined is more than the market rate of the agreement item (to be substituted) the rate payable to the contractor for the substituted item shall be the rate for the agreement item (to be substituted) so increased to the extent of the difference between the market rates of substituted item and the agreement item (to be substituted).

c. If the market rate for the substituted item so determined is less than the market rate of the agreement item (to be substituted) the rate payable to the contractor for the substituted item shall be the rate for the agreement item (to be substituted) so decreased to the extent of the difference between the market rates of substituted item and the agreement item (to be substituted).

d. In the case of contract items, substituted items, contract cum substituted items, the limit of increase shall be 10 % of the stipulated quantities of the contract. If these quantities exceed the limits of 10 % of the stipulated quantities in the contract, the contractor may within fifteen days of receipt of order or occurrence of the excess, claim revision of the rates, supported by proper analysis for the work in excess of the above mentioned limits, provided that if the rates so claimed are in excess of the rates specified in the schedule of quantities the Registrar-in-charge shall within one month of receipt of the claims supported by analysis, after giving consideration to the analysis of the rates submitted by the contractor, determine the rates on the basis of the market rates and the contractor shall be paid in accordance with

the rates so determined.

e. The provisions of the preceding paragraph shall also apply to the decrease in the rates of items for the work in excess of the limits laid in above para, and the Registrar-in-charge shall after giving notice to the contractor within one month of occurrence of the excess and after taking into consideration and reply received from him within fifteen days of the receipt of the notice, revise the rates for the work in question within one month of the expiry of the said period of 15 days having regard to the market rates.

### **GUARANTEE CLAUSE (DLP)**

7.1 The contractor shall guarantee that all the works executed by him shall be free from defects due to faulty, material or workmanship.

7.2 The charge and any shortcomings found in the materials as specified shall be removed at no extra cost. The contractor shall provide the necessary personnel and tools for fulfilling the above guarantee. Period of the guarantee shall be (12) twelve months from the date of issue of completion certificate. During this period any or all components found to be defective shall be replaced or repaired free of cost.

7.3 If the defects are not removed within a reasonable time the IIITDM KURNOOL may arrange to do at the contractor's risk and cost, without prejudice to any other rights.

### **8.1.1. PRICE FALL CLAUSE**

If at any time during the validity of the work the tenderer executes such works as are under this tender. In case of increase in market prevailing prices of the materials if claimed by the supplier, no price escalation will be payable.

### **8.1.2. OTHER CONDITION TO BE ADHERE BY TENDERER**

8.1.2.1 The work is to be carried out as per the specifications in the tender and relevant standards of CPWD.

8.1.2.2 The material should be got approved before start of work.

8.1.2.3 The contractor shall clear the site after completion of work in all respects.

8.1.2.4 All the material used shall be one of the stipulated makes as per approved list of material.

8.1.2.5 The contractor shall comply with safety codes for Fire precaution, health requirement, scaffolds & ladders etc.

8.1.2.6 No T & P shall be issued by IIITDMKURNOOL.

8.1.2.7 All dismantled material for which credit is not being given in the tender shall be handed over to the site engineer stored at proper place.

8.1.2.8 Contractor shall be fully responsible for safety of his workers and incase of any accident / mishap the entire responsibility shall be on the contractor.

8.1.2.9 The work shall be executed without any loss / damage to the IIITDM KURNOOL properties.

8.1.2.10 The picture / drawings provided in the specification is for illustration purposes only and not to

scale.

### **8.1.3. INTERPRETATION**

8.1.3.1. In interpretation of specifications, the following orders shall be as followed: -

- a) Drawings
- b) Technical Specification
- c) Special Conditions of contracts
- d) General condition of contract.

8.1.3.2. Matters not covered by the specification given in this contract as a whole shall be covered by relevant and latest Indian Standard codes/ C.P.W.D code. If such codes on a particular subject have not been framed, the decision of the owner/ owner's representative shall be final and binding.

### **8.1.4. TERMINATION**

8.1.4.1. Being a standing offer, the work can be terminated from either side by serving one month's notice to the other party. However, all the orders placed before the date of serving of such notice will be valid and binding on both the parties. Further, the orders placed under the work can also be terminated individually and the same will not lead to automatic termination of work unless so specified.

#### **8.1.4.2. Termination of work order.**

8.1.4.3 Notwithstanding anything elsewhere provided herein and in addition to any other right or remedy available to IIITDM KURNOOL under the work or otherwise including right of IIITDM KURNOOL to claim compensation for delay, IIITDM KURNOOL may, without prejudice to his right against contractor in respect of any delay, bad workmanship or otherwise or to any claims for damage in respect of any breaches of the contract and without prejudice to any rights or remedies under any of the provisions of this work or otherwise and whether the date for completion has or has not elapsed by intimation in writing, absolutely determine and terminate the Contract. Default or failure by the contractor in any of the under mentioned cases, including but not limited to the following shall be the basis of taking action under this clause of the contract.

- 1) Failure to provide at the job site, sufficient labor, material, equipment, machinery, and / or facilities, required for the proper and / or due execution of the work or any part thereof:
- 2) Failure to execute the works or any of them in accordance with the contract.
- 3) Disobedience of any order or instruction of the Site Engineer and /or Engineer-in-charge.
- 4) Negligence in carrying out the work or carrying out of work found to be unsatisfactory by the Registrar -incharge.
- 5) Abandonment of the works or any part thereof.
- 6) If the Contractor misconduct in any manner.

7) Delay in execution of work, which in opinion of Registrar-in-charge shall delay the completion of work beyond the stipulated date of completion.

8) Distress, execution, or other legal process being levied on or upon any of the Contractors goods and /or assets.

9) Death of Contractor (if an individual).

10) If the Contractor of any person employed by him shall make or offer for any purpose connected with the contract any gift, gratuity, royalty, commission, gratification or other inducement (whether money or in any other form) to any employee or agent to IIITDM Kurnool.

8.1.4.4 The decision of the Director, IIITDM KURNOOL as to whether any of the events/ contingencies mentioned in aforesaid clauses entitling IIITDM KURNOOL to terminate the contract has occurred shall be final and binding upon the Contractor. The jobs left however by the Contractor shall be got done at his risk and cost through the other agencies and the Contract shall be determined accordingly.

#### **8.1.5. FORCE MAJEURE**

8.1.5.1 The right of the contractor to proceed with the work shall not be terminated because of any delay in the completion of the work due to unforeseeable causes beyond the control and without the fault or negligence of the contractor, including but not limited to acts of god, or of the public enemy, restraints of a sovereign state, floods, unusual severe weather conditions.

#### **8.1.6. Arbitration**

All disputes of any kind arising out of supply, commissioning, acceptance, warranty maintenance etc., shall be referred by either party (IIITDM Kurnool or the bidder) after issuance of 30 days' notice in writing to the other party clearly mentioning the nature of dispute and will be referred to the arbitrator to be nominated by The Registrar, IIITDM Kurnool. The Venue for arbitration shall be Vijayawada/ Hyderabad, India.

Sd/-

REGISTRAR In charge.

**PART – E (TECHNICAL DETAILS)**

## SCOPE OF WORK

Name of work: - “Providing and Fixing Aluminum Partition works in Library and other labs at IITDM kurnool”.

### Providing and fixing Aluminum partitions in Library and other labs.

- Sizes of Partitions in Library: a) 10'6" x 10'0" (with door)  
B) 2 x 12'0" x 11'6"  
c) 10'6" x 11'6" (with door)
- Size of partitions for 7 Nos. cubicals: a) 7 x 11'0" x 11'6"
  - B) 7 x 8'0" x 10'0" (with door)
- Size of partition in store 1: 5'0" x 10'0"
- Size of partition in Store 2: 3'0" x 11'0"
- Size of Door: 3'0" x 7'0"
- Area of Aluminum Partition – 1815 Sq.Ft Area of Doors – 231 sq. Total – 2046 Sq.Ft
- Frame section – 2 ½ "x 1 ½ "x 1.5mm Th
- Door Section – Top, Verticals, Centre – 1 ¾ "x 1 ¾ "x 1.5mm Th
  - Bottom – 4" x 1 ¾ "x 1.5mm Th
- Glass (4' height) – 5mm Thick plain glass (Saint Gobin / Modi Flote)
- 4.12mm prelaminated particle board (Both sides ivory color lamination)
- Brass body door lock and with all necessary fixtures like handles, hinges, door closers, etc.

### 2. Glass partition:

- Size of partition in Director's Chamber : 3'8" x 10'0" (with door), Area – 36.6 sq.ft
- Specifications: 12mm plain glass (Saint Gobin / Modi Flote) fixed with necessary fittings for partition and door.

Sd/-

Registrar -in-charge.

## **GENERAL SPECIFICATIONS**

1. Specifications of all material to be used should be compliance to relevant codes of Bureau of Indian Standards (BIS).
2. ISI marked material shall be used wherever applicable.
3. For standard makes or variety of materials the samples shall be got approved from the Registrar-in charge in advance.
4. Each board may also be marked with standard mark governed by the BIS Act, 1986.
5. A sample of every item of furniture or as directed by the Registrar-In-Charge, including its parts shall be submitted for approval before an order is placed or manufacture commences. Approved samples shall be used as standards of finish and workmanship.

**Note: -Specifications mentioned above are indicative. CPWD specifications to be followed for further reference.**

**Sd/-**

**Registrar Incharge.**



**PART –G (Price Bid)**

**PRICE BID****Providing and Fixing Aluminum Partition works in Library and other labs at IITDM kurnool**

S.no	Description of the Item	Unit	Qty	Rate	Amount
1	Providing and fixing of Partitions in Library : a) 10'6" x 10'0" (with door) b) 2 x 12'0" x 11'6" c) 10'6" x 11'6' (with door)	Sq.Ft	502		
2	Providing and fixing of partitions for 7 Nos. cubicals : a) 7 x 11'0" x 11'6" b) 7 x 8'0" x 10'0" (with door)	Sq.Ft	1446		
3	Providing and fixing of partition in store 1 : 5'0" x 10'0"	Sq.Ft	50		
4	Providing and fixing of partition in store 2: 3'0" x 11'0"	Sq.Ft	33		
5	Total Area of Aluminum Partition(Excluding Door Area)	Sq.ft	1800		
6	Providing and fixing of Door : 3'0" x 7'0"	Sq.ft	21		
7	Total Area of 11 Doors	Sq.Ft	231		
8	Providing and fixing of partition in Director's Chamber : 3'8" x 10'0" (with door)	Sq.Ft	36		
	Total Inclusive of all Taxes				

## **PART – H (Annexures)**

**ANNEXURE-I**

**APPLICATION FORM**

[NOTE: On the letterhead of the applicant including full postal address, email address, telephone no. and fax no.]

Date: \_\_\_\_\_

The Director,  
IIITDM Kurnool

Sirs,

1. Being duly authorized to represent and act on behalf of ..... (Hereinafter referred to as “the Applicant”) and having reviewed and fully understood all the pre-qualification information provided, the undersigned hereby applies to be pre-qualified by yourselves as a tenderer for award of work(s) for --  
-----

2. Attached to this letter are copies or original documents defining:

(a) the applicant’s legal status

(b) the principal place of business

(c) the place of incorporation (for applicants who are corporations) or the place of registration and the nationality of the owners (for applicants who are partnerships or individually owned firms)

(d) Annexure no. II to VII

3. Your agency and its authorized representatives are hereby authorized to conduct any inquiries or investigations to verify the statements, documents and information submitted in connection with this application, and to seek clarification from our bankers and clients regarding any financial and technical aspects. This letter of application will also serve as authorization to any individual or authorized representative or any institution referred to in the supporting information, to provide such information deemed necessary and requested by you to verify statements and information provided in this application, or with regard to the resources, experience, and competence of the Applicant.

4. Your agency and its authorized representatives may contact the following persons for further information on general, personnel, technical and financial enquiries.

Contact 1: Name, email and Phone no.

Contact 2: Name, email and phone no.

5. This application is made with the full understanding that:

(a) Bids submitted by applicants will be subject to verification of all information submitted at the time of bidding

(b) Your agency reserves the right to:

- amend the scope and value of the contract / bid under this project; in such event, bids will only be called from pre-qualified bidders who meet the revised requirements; and
- reject or accept any application, cancel the pre-qualification process, and reject all applications without assigning reasons or incurring any liability thereof; and

(c) Your agency shall not be liable for any such actions and shall be under no obligation to inform the applicant.

6. The undersigned declares that statements made and the information provided in the duly completed application are true and correct in every detail.

Signed and sealed, Name .....

For and on behalf of.....

**ANNEXURE-II**

**GENERAL INFORMATION**

1	Name of firm
2	Head office address
3	Telephone
4	E-mail No.
5	Place of incorporation / Year of Incorporation / Registration

**Signature and seal of the Authorized Signatory of the bidder**

**ANNEXURE – III**

Financial Year	Annual Turn Over in Indian Rupees (or equivalent to Indian Rupees) as per Audited Balance Sheet
2016-2017	Rs.
2017-2018	Rs.
2018-2019	Rs.

**NOTE: The above data is to be supported by audited balance sheets**

Attach recent solvency certificate from bankers. The certificate should be not more than one-year-old from the date of submission of bid.

Signature and seal of the Authorized Signatory of the bidder.

**Annexure-IV**

**Solvency certificate**

This is to certify that to the best of our Knowledge and information M/s ..... having marginally noted address, a customer of our bank are/is respectable and can be treated as good for any engagement up to a limit of Rs. .... (Rupees.....)

This certificate is issued without any guarantee or responsibility on the bank or any of the officers.

Date of Issue: -

(Signature with Stamp)

For the Bank

Note-

1. Banker's certificate should be on letter head of the Bank and should not be more than 6 months old from the date of publication of tender.
2. In case of partnership firm, certificate should include names of all partners as recorded with Bank.



**ANNEXURE -V**

**EXPERIENCE OF COMPLETION OF PROJECTS OF SIMILAR NATURE & COMPLEXITY**

(During last three years ending last day of month previous to the one in which applications are invited)

Sl. No	Name of work / project and location	Owner or sponsoring organization	Cost of work in Lakhs	Date of commencement as per contract	Stipulated date of completion	Actual date of completion	Name and address/ telephone number of officer to whom reference be made	Remarks

NOTE: Please attach supporting documents (completion certificates along with order copies) for the above information

**Signature and seal of the Authorized Signatory of the bidder**

Annexure -VI

CERTIFICATE FOR SITE INSPECTION

Certified that we..... (Name of tenderer) have visited the site on dated..... and assessed the nature and amount of work involved before submitting our offer. We will be able to complete the works within the stipulated time and also certified that we will be able to supply the material/executing the work as per specification to suit the site conditions.

Address of site:

**Indian Institute of Information Technology, Design and Manufacturing Kurnool  
Jagnnathagattu,  
Dinnidevarapadu,  
Kurnool,  
Andhrapradesh-518007**

Signature of Tenderer with Seal & Date

Annexure -VII

FORM OF AGREEMENT

This Agreement made the \_\_\_\_\_ day of \_\_\_\_\_ 20\_\_\_\_\_ between Indian Institute of Information Technology Design and Manufacturing, Kurnool for entering into the work(s) for "Providing and Fixing ----- at IIITDM Kurnool" (hereinafter called "The Employer" ) who enters into this Agreement of the one part and M/s..... (Hereinafter called "The Contractor") of the other part.

Whereas the Employer is desirous that certain works should be executed by the Contractor, viz \_\_\_\_\_ ("the Works") and has accepted a Bid by the Contractor for the execution and completion of the works and the remedying of any defects therein

Now this Agreement witnessed as follows:

1. In this Agreement words and expressions shall have the same meanings as are respectively assigned to them in the Conditions of Contract hereinafter referred to.
2. The following documents shall be deemed to form and be read and construed as part of this Agreement, viz:
  - (a) The Letter of Award;
  - (b) The said Bid;
  - (c) The General Conditions of Contract;
  - (d) Prequalification document
  - (e) Instructions to Tenderers and Specific Conditions of Contract;
  - (f) The Specification;
  - (g) The Drawings;
  - (h) The Priced Bid
  - (i) Any other relevant documents referred to in this Agreement or in the aforementioned documents.
3. In consideration of the payments to be made by the Employer to the Contractor as hereinafter mentioned, the Contractor hereby covenants with the Employer to execute and complete the Works and remedy any defects therein in conformity in all respects with the provisions of this work.

4. The Employer hereby covenants to pay the Contractor in consideration of the execution and completion of the Works and the remedying of defects therein the Contract Price or only such other sums as may become payable under the provisions of the Contract at the times and in the manner prescribed by the Contract.

In Witness whereof the parties hereto have caused this Agreement to be executed the day and year first before written.

Signed, Sealed, and Delivered by the Said

\_\_\_\_\_

Binding Signature for and on behalf of IIITDM KURNOOL

Binding Signature of Contractor \_\_\_\_\_

In the presence of

Witness (1):

Witness (2)

PARTITION DETAILS

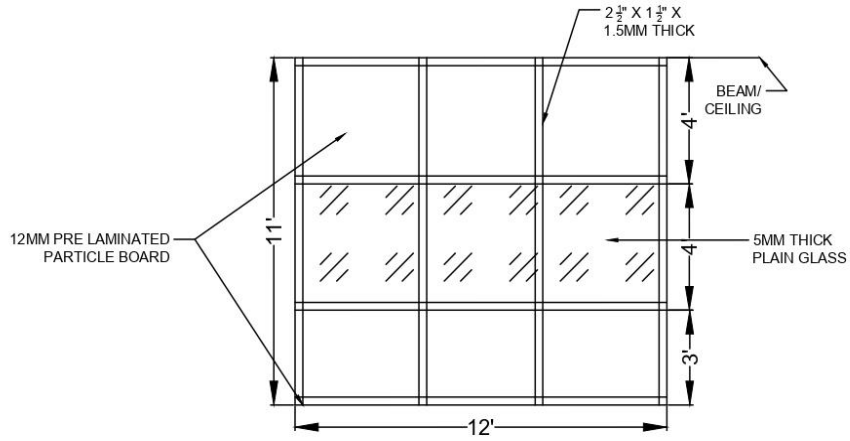

DIRECTOR CHAMBER

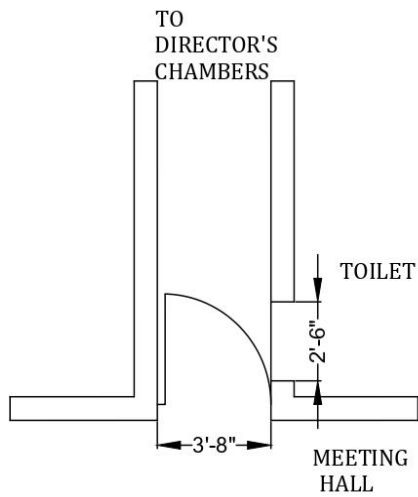

DOOR

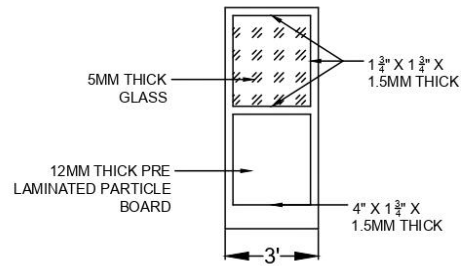

LIBRARY

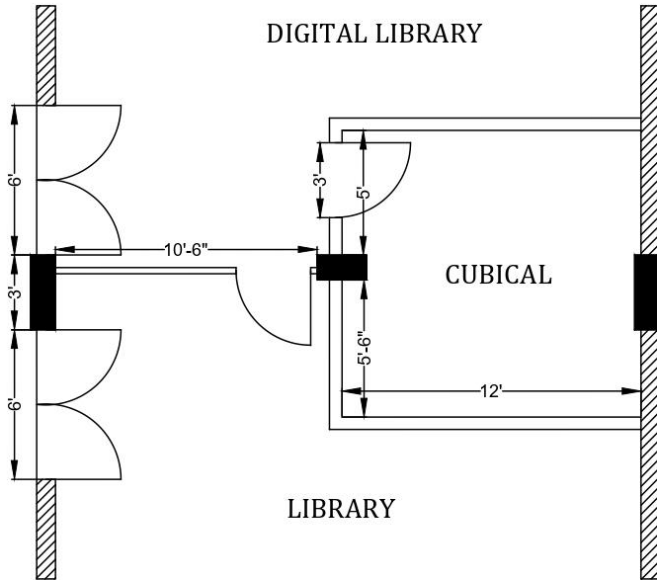

STORE 1

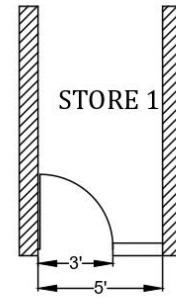

CUBICAL

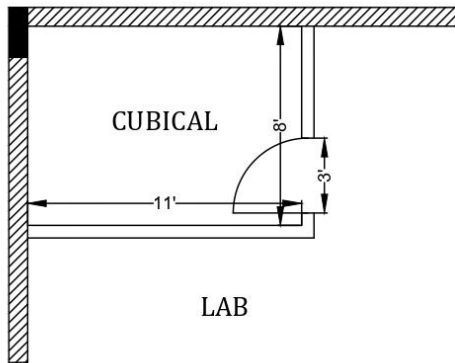

STORE 2

